

Summary

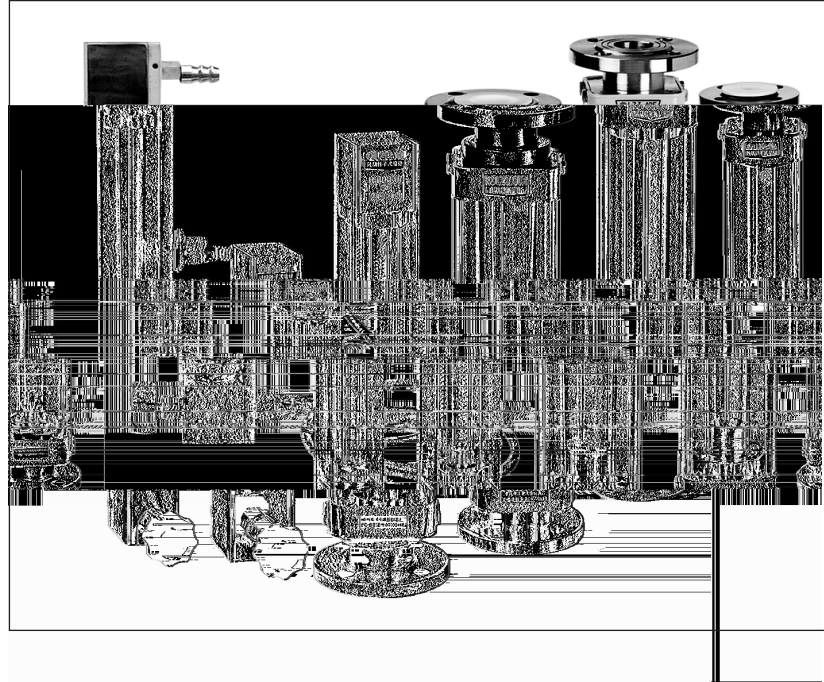

Principle & Structure

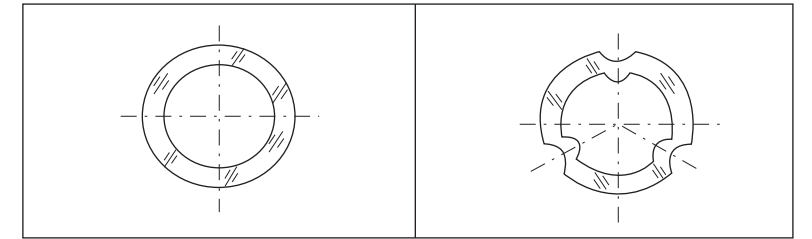
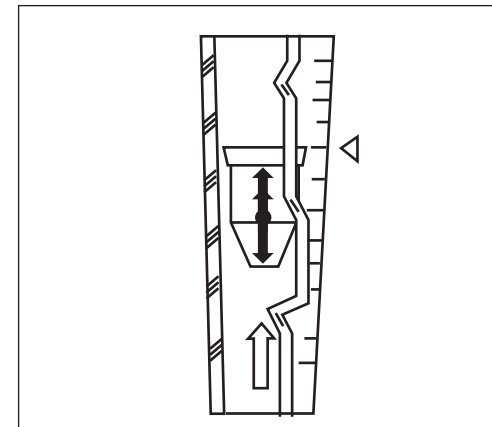
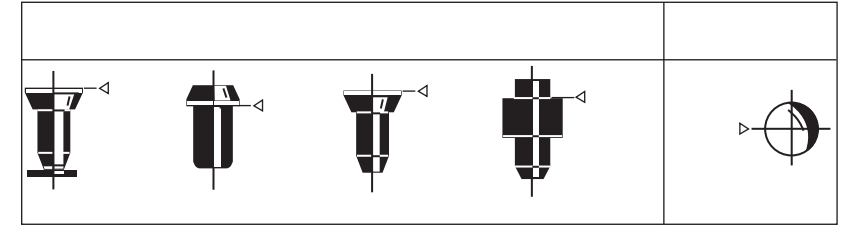

The profile and installing dimensions

			∅		
			∅		
			∅		
∅	∅	∅	∅	∅	
∅	∅	∅	∅	∅	
∅	∅	∅	∅	∅	
∅	∅	∅	∅	∅	
∅	∅	∅	∅	∅	
∅	∅	∅	∅	∅	

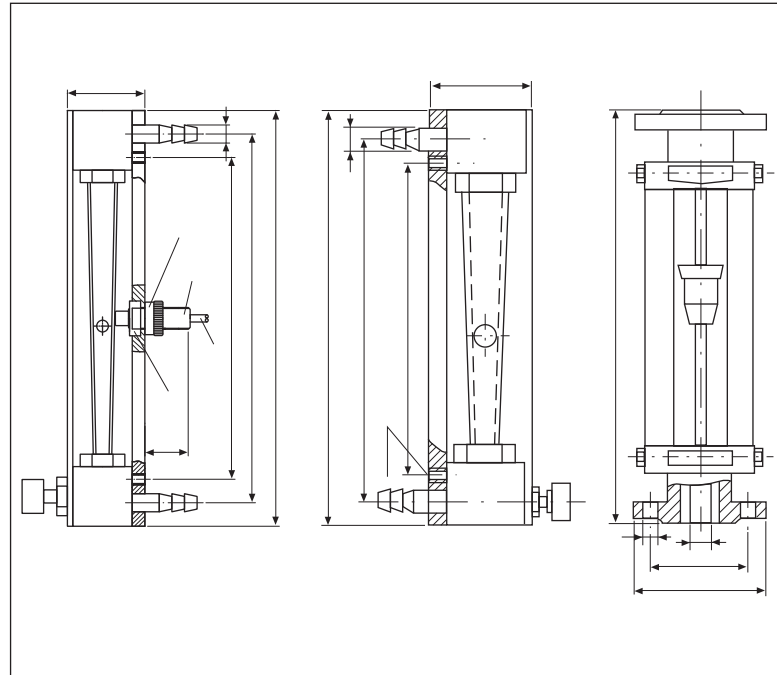

The material of the parts touching the fluid measured



